

elastic  
horizontally split cover



32-1

## Features

- High nominal torques up to 335 500 Nm
- Compensation of axial, radial and angular misalignments
- Gradual increase in torsional rigidity as torques increase
- Horizontally split cover
- Easy replacement of the grid
- Typical application: Crushers, reels, mills, calenders, mixers, belt drives

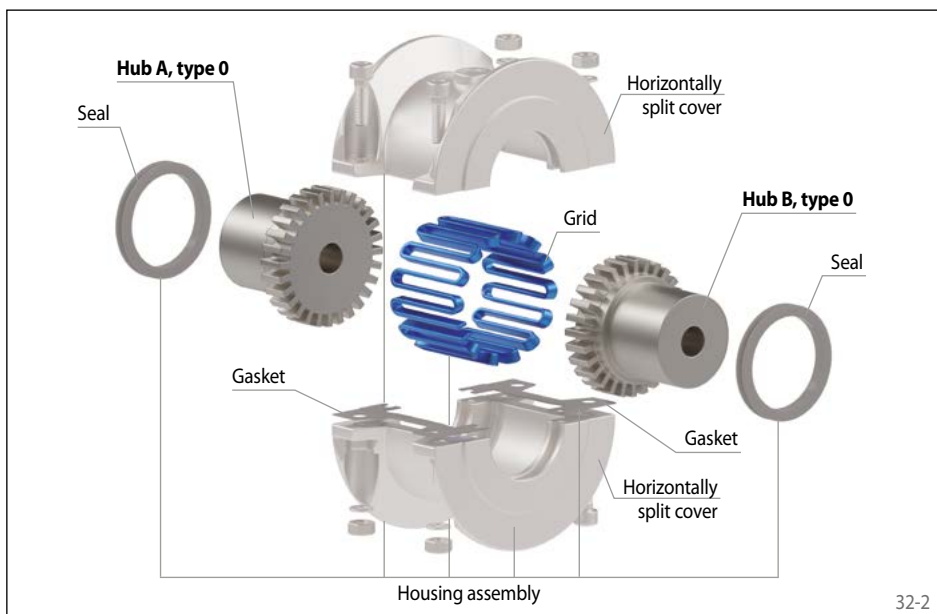

32-2

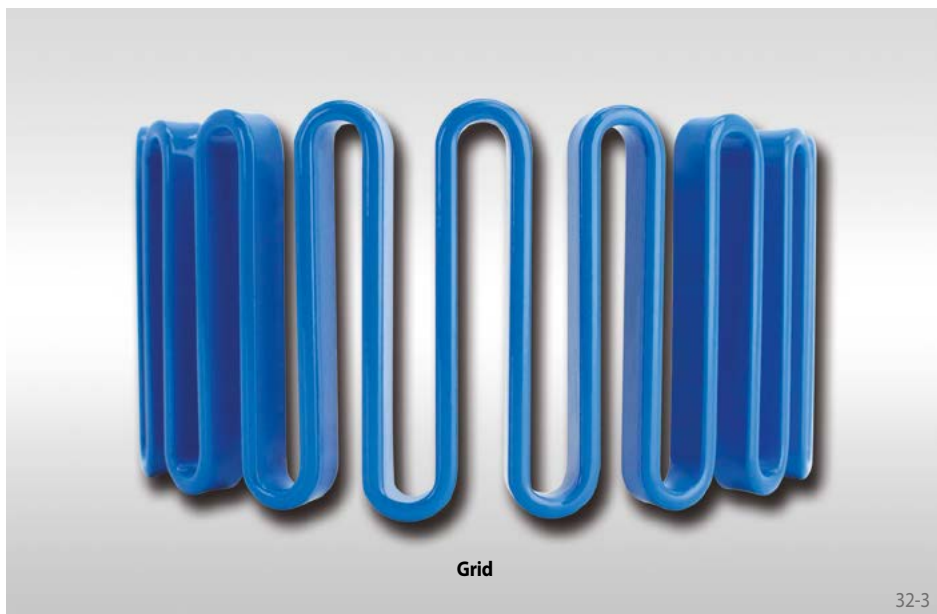

Grid

32-3

## Order example

	Code
Coupling design	RES
Coupling size	1030
Type	EYO
Material of the hub: • Steel	STA
Hub A, type: • 0, standard	0
Hub A, design: • finish bored with keyway • roughbored	FB VA
Bore diameter hub A	025
Hub B, type: • 0, standard	0
Hub B, design: • finish bored with keyway • roughbored	FB VA
Bore diameter hub B	032
Grid	ST00

RES 1030 EYO-STA-0FB025-0FB032-ST00

elastic  
horizontally split cover

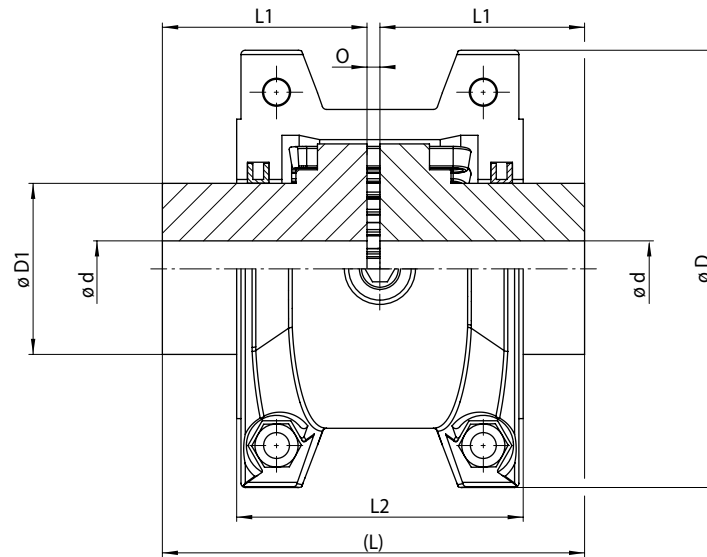

33-1

Coupling size	Nominal torque $T_{KN}$ Nm	Nominal power at $100 \text{ min}^{-1}$ $P_{K100}$ kW	Max. speed $n_{max}$ $\text{min}^{-1}$	Pilot bore $d^*$ mm	Bore $d^*$		D mm	D1 mm	L mm	L1 mm	L2 mm	O mm	Permissible misalignments			Weight grease filling kg	Weight with max. bore kg
					min. mm	max. mm							Axial mm	Radial mm	Angular °		
1020	48	0,50	4500	-	13	28	101,5	39,7	98,0	47,5	66,5	3,0	±0,3	0,3	0,25	0,03	1,9
1030	136	1,42	4500	-	13	35	110,0	49,2	98,0	47,5	68,0	3,0	±0,3	0,3	0,25	0,03	2,6
1040	226	2,36	4500	-	13	43	117,5	57,1	104,5	51,0	70,0	3,0	±0,3	0,3	0,25	0,05	3,4
1050	395	4,14	4500	-	13	50	138,0	66,7	123,5	60,0	79,5	3,0	±0,3	0,4	0,25	0,05	5,4
1060	620	6,50	4350	-	20	56	150,5	76,2	130,0	63,5	92,0	3,0	±0,3	0,4	0,25	0,09	7,3
1070	900	9,46	4125	-	20	67	162,0	87,3	155,5	76,0	95,0	3,0	±0,3	0,4	0,25	0,11	10,0
1080	1860	19,51	3600	-	27	80	194,0	104,8	181,0	89,0	116,0	3,0	±0,3	0,4	0,25	0,17	18,0
1090	3380	35,47	3600	-	27	95	213,0	123,8	200,0	98,5	122,0	3,0	±0,3	0,4	0,25	0,25	25,0
1100	5700	59,71	2400	-	42	110	250,0	142,0	245,5	120,5	155,5	4,5	±0,45	0,4	0,25	0,43	42,0
1110	8400	88,67	2250	-	42	120	270,0	160,3	258,5	127,0	161,5	4,5	±0,45	0,5	0,25	0,51	54,0
1120	12400	130,05	2025	57	61	140	308,0	179,4	304,5	149,5	191,5	6,0	±0,6	0,5	0,25	0,73	81,0
1130	18000	189,17	1800	57	67	170	346,0	217,5	330,0	162,0	195,0	6,0	±0,6	0,56	0,25	0,91	121
1140	25900	271,93	1650	57	67	200	384,0	254,0	371,5	183,0	201,0	6,0	±0,6	0,56	0,25	1,13	178
1150	36100	378,34	1500	57	108	215	453,0	269,2	372,0	183,0	271,0	6,0	±0,6	0,56	0,25	1,95	234
1160	50500	532,04	1350	57	121	240	501,5	304,8	402,0	198,0	279,0	6,0	±0,6	0,6	0,25	2,81	317
1170	67500	709,38	1225	65	134	280	566,5	355,6	438,0	216,0	304,0	6,0	±0,6	0,6	0,25	3,49	448
1180	93500	983,68	1100	105	153	300	630,0	393,7	483,5	239,0	321,0	6,0	±0,6	0,76	0,25	3,76	619
1190	124000	1300,53	1050	105	153	335	675,5	436,9	524,5	259,0	325,0	6,0	±0,6	0,76	0,25	4,40	776
1200	169000	1773,46	900	105	178	360	757,0	497,8	565,0	279,5	355,5	6,0	±0,6	0,76	0,25	5,62	1058
1210	248500	2605,47	820	105	178	390	844,5	533,4	622,5	305,0	432,0	12,7	±0,6	0,76	0,25	10,5	1424
1220	335500	3515,89	730	105	203	420	920,5	571,5	663,0	325,1	490,0	12,7	±0,6	0,76	0,25	16,1	1785

For finish bores, please specify bore diameter hub A and hub B. Tolerance of finish bores H7. Keyways in accordance with DIN 6885, sheet 1. Keyway tolerance JS9.  
\* Bores also available in inch size, see page 65.