

Installation and operating instructions for Brake DT XXX FEA-XXX H-ST

E 09.793e



RINGSPANN GmbH

Schaberweg 30-38
61348 Bad Homburg
Germany

Phone +49 6172 275 0
Fax +49 6172 275 275

www.ringspann.com
info@ringspann.com

RINGSPANN	Installation and operating instructions for Brake DT XXX FEA-XXX H-ST spring activated – electro hydraulically released	E 09.793e			
Issue: 12.05.2021	Version: 2	Drawn: BAHS	Checked: EISF	Pages: 22	Page: 2

Important

Please read these instructions carefully before installing and operating the product. Your particular attention is drawn to the notes on safety.

These installation and operating instructions are valid on condition that the product meets the selection criteria for its proper use. Selection and design of the product is not the subject of these installation and operating instructions.

Disregarding or misinterpreting these installation and operating instructions invalidates any product liability or guarantee by RINGSPANN; the same applies if the product is taken apart or changed.

These installation and operating instructions should be kept in a safe place and should accompany the product if it is passed on to others -either on its own or as part of a machine- to make it accessible to the user.

Safety Notice

- Installation and operation of this product should only be carried out by skilled personnel.
- Repairs may only be carried out by the manufacturer or accredited RINGSPANN agents.
- If a malfunction is indicated, the product or the machine into which it is installed, should be stopped immediately and either RINGSPANN or an accredited RINGSPANN agent should be informed.
- Switch off the power supply before commencing work on electrical components.
- Rotating machine elements must be protected by the purchaser to prevent accidental contact.
- Supplies abroad are subject to the safety laws prevailing in those countries.

This is a translation of the German original version!

In case of inconsistencies between the German and English version of this installation and operating instruction, the German version shall prevail.

RINGSPANN	Installation and operating instructions for Brake DT XXX FEA-XXX H-ST spring activated – electro hydraulically released			E 09.793e	
	Issue: 12.05.2021	Version: 2	Drawn: BAHS	Checked: EISF	Pages: 22 Page: 3

Contents

1. General notes

- 1.1 General safety instructions
- 1.2 Special safety instructions

2. Design and function / parts list

- 2.1 Function
- 2.2 Identification
- 2.3 Drawing and parts list

3. Intended use

4. Impermissible use

5. Condition as delivered

6. Handling and storage

7. Technical prerequisite for reliable operation

8. Installing the RINGSPANN brake

- 8.1 General instructions regarding assembly and installation
- 8.2 Assembly description
- 8.3 Adjusting / readjusting the brake pad distance

9. Start-up

10. Disassembling the brake

11. Maintenance

- 11.1 General maintenance
- 11.2 Permissible friction lining wear and exchanging of the brake pad

12. Options

- 12.1 Mounting and connection of micro switch for position monitoring and pad wear control
- 12.2 Handrelease

RINGSPANN	Installation and operating instructions for Brake DT XXX FEA-XXX H-ST spring activated – electro hydraulically released			E 09.793e	
Issue: 12.05.2021	Version: 2	Drawn: BAHS	Checked: EISF	Pages: 22	Page: 4

1. General notes

1.1 General safety instructions

Read these installation/operating instructions carefully before putting the brake into operation. Consider these instructions as well as the drawings in the individual sections.

All work with and on the brake is to be carried out taking into account that "safety is top priority".

Switch the drive unit off before carrying out work on the brake.

Rotating parts (e.g. brake drum) must be secured by the operator against unintentional touching.

1.2 Special safety instructions



Life-threatening danger!

When assembling, operating and maintaining the brake it is to be ensured that the entire drive train is secured against being switched on unintentionally. Moving parts can cause severe injury. Rotating parts (e.g. brake drum) must be secured by the operator against unintentional touching.

Strongly pre-loaded pressure springs are installed in the springed thrusters of the brake. The springed thruster may only be disassembled by the factory.

2. Design and function / parts list

2.1 Function

The brake is a machine element with which accelerated masses can be safely slowed down. In combination with a brake drum, you have a complete brake for the effective safeguarding of machines and systems. Thanks to its universal design, it fulfils the following functions:

- As a holding brake, it prevents a stationary shaft from starting unintentionally.
- As a stopping brake, it brings a rotating shaft to a halt.

The braking force is produced by springs, and the brake is opened electro hydraulically.

At the standard brake FEA with automatic adjustment if pad wear appears, the automatic adjustment works and no wear adjustment is necessary to pre-load the springs in the thruster. The readjustment is only necessary to adjust the gap on each side between the friction pad and brake drum.

RINGSPANN	Installation and operating instructions for Brake DT XXX FEA-XXX H-ST spring activated – electro hydraulically released	E 09.793e		
Issue: 12.05.2021	Version: 2	Drawn: BAHS	Checked: EISF	Pages: 22 Page: 5

2.2 Identification

These operating instructions apply:

- With signal transmitter installation.
- With different friction block variants (higher sliding speed, double friction surface or special friction materials).
- With special frame.
- With internal throttle valve can adjust delay time.
- With micro-switch wear control and status control.
- With hand release lever.

There is a type plate on the brake and the thruster. The exact design of the brake and the thruster is defined by this type plates it shows model name, options in shortcuts, serial number, manufacture year, main characteristics.

As well as these instructions, please also consider the catalogue data for the brake at www.ringspann.com and the drawings in the individual sections.

2.3 Drawing and parts list

Overview illustration of brake DT XXX FEA-XXX H-ST NC with all options for details look into catalog.

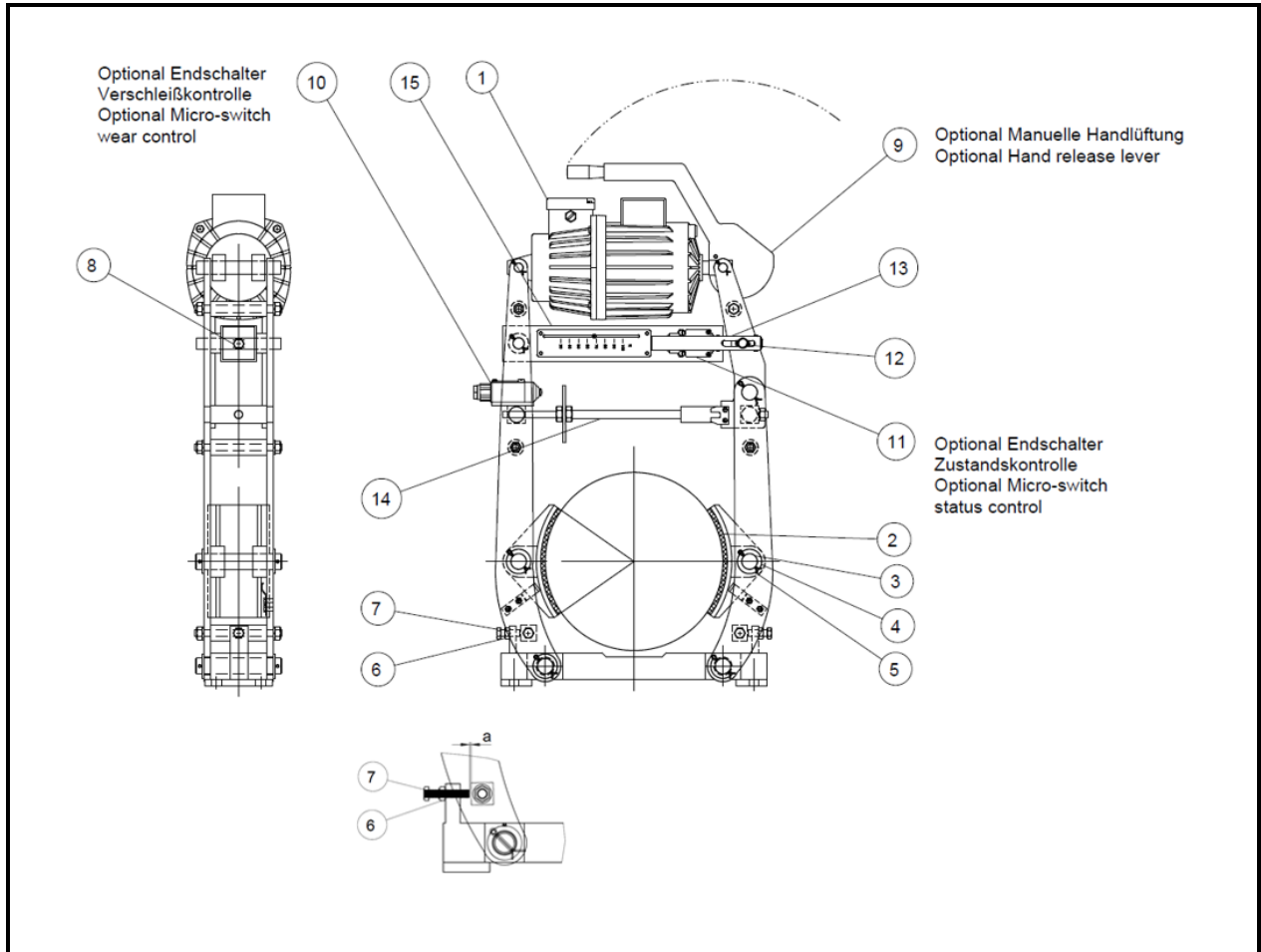

Fig. 2.1

Part	Designation	Quantity
1	Thruster	1
2	Brake pad	2
3	Axes brake pad	2
4	Washer	4
5	Split pin	4
6	Nut	2

RINGSPANN	Installation and operating instructions for Brake DT XXX FEA-XXX H-ST spring activated – electro hydraulically released			E 09.793e	
	Issue: 12.05.2021	Version: 2	Drawn: BAHS	Checked: EISF	Pages: 22 Page: 7

7	Adjust screw	2
8	Adjusting nut adjustable brake spring	1
9	Hand release lever (optional)	1
10	Micro-switch wear control (optional)	1
11	Micro-switch status control (optional)	1
12	Nut for adjusting part	1
13	Adjusting part	1
14	Adjusting spindle	1
15	External adjustable brake spring	1

3. Intended use

The brake has been designed for use as a holding and stopping brake IP class 56.
The brake is suitable for upright installation on horizontal plain.
Use for any other purpose will be deemed as improper.

4. Impermissible use

It is not permissible to operate the brake with another voltage than prescribed in the technical catalogue data or with other media. Unauthorised constructional changes to the brake are also not allowed.

5. Condition as delivered

The brake is tested prior to delivery. The brake is delivered not ready to install. Ordered micro switch are already installed.

When delivered, the clamping gap of the brake between the brake pad and the brake drum has to be adjust. When the brake is applied, the brake pad has to be adjust on each side with a gap of 1.5mm.

6. Handling and storage

The technical data of the brake such as clamping force, oil volume, dimensions and weight are shown on the catalogue pages for the brake. The current data can also be found on the RINGSPANN website www.ringspann.com.

RINGSPANN	Installation and operating instructions for Brake DT XXX FEA-XXX H-ST spring activated – electro hydraulically released	E 09.793e	
Issue: 12.05.2021	Version: 2	Drawn: BAHS	Checked: EISF Pages: 22 Page: 8

The brake is delivered in preserved condition and can be stored for 12 months in an enclosed and dry place. It is to make sure that no condensation develops. Damp storage rooms are not suitable. If storing the brake for a period longer than 12 months, as well as after any transport, the brake must be activated once in order to prevent the seals from getting stuck down. Please note if you use the FEA automatic brake without brake drum do not often switch the brake otherwise the automatic will work and the brake pad wear compensation start its adjustment process.

7. Technical prerequisite for reliable operation

Fastening the brake on low vibration stability machine parts will ensure quiet braking without creaking.

8. Installing the RINGSPANN brake

8.1 General instructions regarding assembly and installation

Before installing the brake, the brake drum must be cleaned with alcohol (e.g. spirit (ethanol) or isopropyl alcohol) or with water-based tenside solutions (soapy water or the like).

If cleaning the brake drum with a diluent, acetone or brake cleaning agent, it must be ensured that these agents and no residues of these agents come into direct contact with the brake pads. This must be ensured for pure holding brakes in particular, since no dynamic braking takes place that would remove any diluent residues from the brake drum.



Important!

Residues from oil and anti-rust agent considerably reduce the coefficient of friction and thus also the braking and holding torque!

8.2 Assembly description

Thrusters are always supplied complete with their oil filling HL10 to standard DIN 51524. The most employed oil mark is AGIP ACER MV10. Time by time, check out the oil level through the oil level control plug and eventually add it through the oil drain plug.

For application options heat resistance up to 100°C design and down to low temperature -40°C, use the oil indicated on the type plate thrustor.



Information!

The service life of the brake system will extend depending on how high the purity of the oil is.

RINGSPANN	Installation and operating instructions for Brake DT XXX FEA-XXX H-ST spring activated – electro hydraulically released	E 09.793e		
Issue: 12.05.2021	Version: 2	Drawn: BAHS	Checked: EISF	Pages: 22 Page: 9



Important!

Leaked oil must be completely removed. Leaks are to be removed immediately!

Before mounting onto the brake drum, the brake caliper must be released (opened) and adjusting the distance pad to the brake drum. This can be done by:

- Connecting the electrical connection and activate the brake
- Hand release (optional)
- Loosen the adjusting spindle (item 14) in order to unreleased the brake for assembly
- Adjusting the distance 1.5 free gap between pad and brake drum

The standard brake callipers are fastened to the machine part with 4 screws of strength class 8.8 or higher. (The screws are not included in the scope of supply. Please see the catalogue pages for quantities, sizes and lengths).



Information!

The installation of the brake if the drivetrain: motor, gearbox, something else and the brake drum is already installed or you will change to a new brake if the brake is already installed. The exchange or installation of the brake is easy remove the down bolt of the right arm connection to the basement see Fig. 10.1. Before you remove the bolt please remove one split pin and the two locking group screws for the bolt in the basement and then you can swing the arm aside replace the brake. The installation use the other way around. Please secure the two group screws with screw locking.



Caution - danger of injury!

If the brake is open with the electrical switch, do not switch the brake during assembly, the brake can suddenly close!

Before assembly it is to be checked that the customer connection part is even and the mounting surface of the brake is within a tolerance of 0.1 mm.

The connecting plate for the brake as well as the brake drum must be checked for dimensional accuracy. For this purpose, the connection dimensions shown on the catalogue data sheet or installation drawing must be checked.

The surface has to be even only for the contact surface to the customer connection part for all dimension look into the catalogue.

The supporting plane must lie in distance of $h \pm 0,1$ from the drum axle.

Examine the axial movement of the brake drum.

The axial movement must not be greater than ± 0.1 mm.

The maximum permissible lateral run-out of the brake drum is 0.1 mm.
A greater lateral run-out can cause the brake unit to rattle and shake.

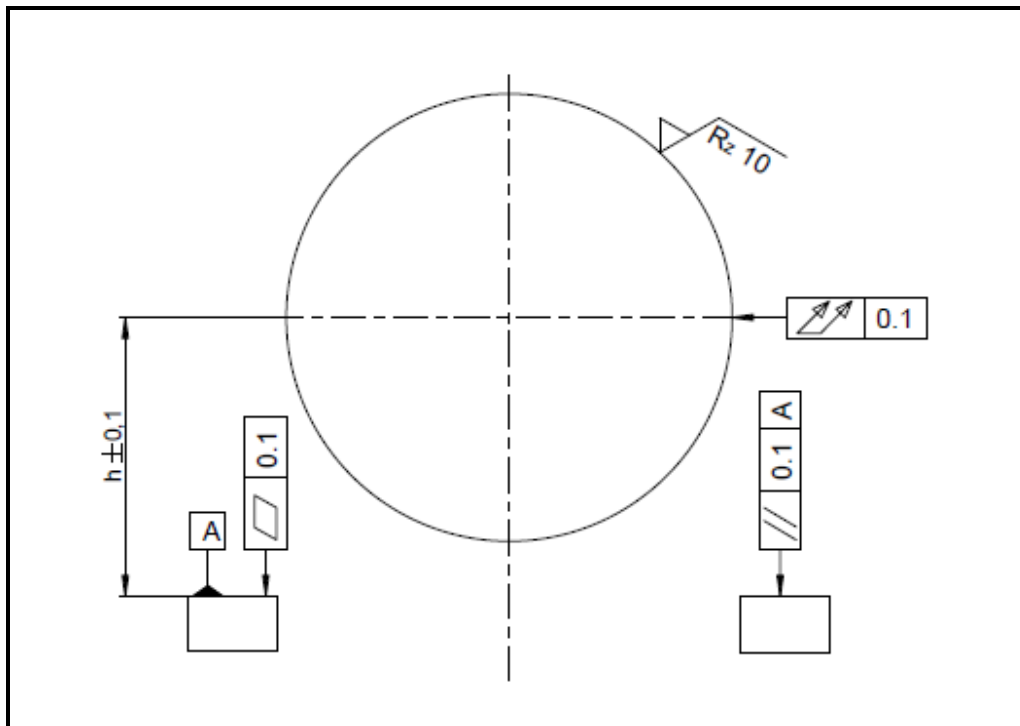

Fig. 8.1

**Important!**

Check if the brake disc can be rotate freely.

RINGSPANN	Installation and operating instructions for Brake DT XXX FEA-XXX H-ST spring activated – electro hydraulically released	E 09.793e			
Issue: 12.05.2021	Version: 2	Drawn: BAHS	Checked: EISF	Pages: 22	Page: 11



Important!

If the brake calliper is manually released, this manual release must be removed again to ensure a functional brake!

Electric connection: The cable may entry from both sides of terminal box. The gland size is Pg11 for 451 thruster and Pg16 for all others thruster. Since the sense of rotation doesn't affect the thruster's function you don't need to respect any sequence by connecting the 3 phases. Tension swings of $\pm 10\%$, even small changes in frequency affect the lifting force. Direct parallel connection with crane motor should be avoided.

Don't switch on before having closed the terminal box cover and having connected the earth wire.



Important!

Don't activate the brake before having closed the terminal box cover and having connected the earth wire!

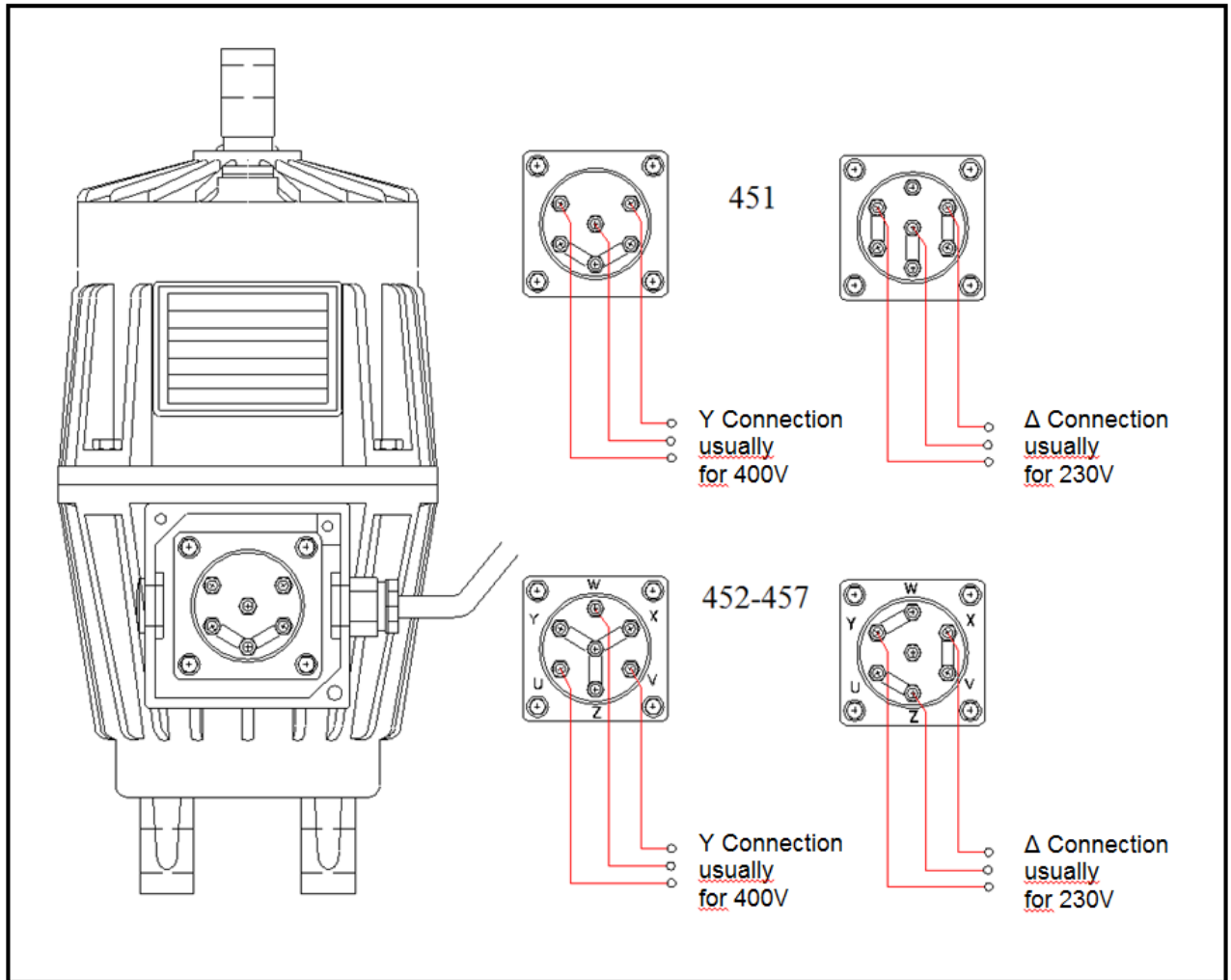

Fig. 8.2

8.3 Setting / adjusting of the brake pad distance

The brake pad distance is set after the brake calliper has been assembled and after pad wear through adjusting / readjusting, see Fig. 2.1.

The setting/adjusting process of the FEA version automatic brake has to be carried out only by using the two-adjusting screw (item 7), shown in Fig. 2.1.

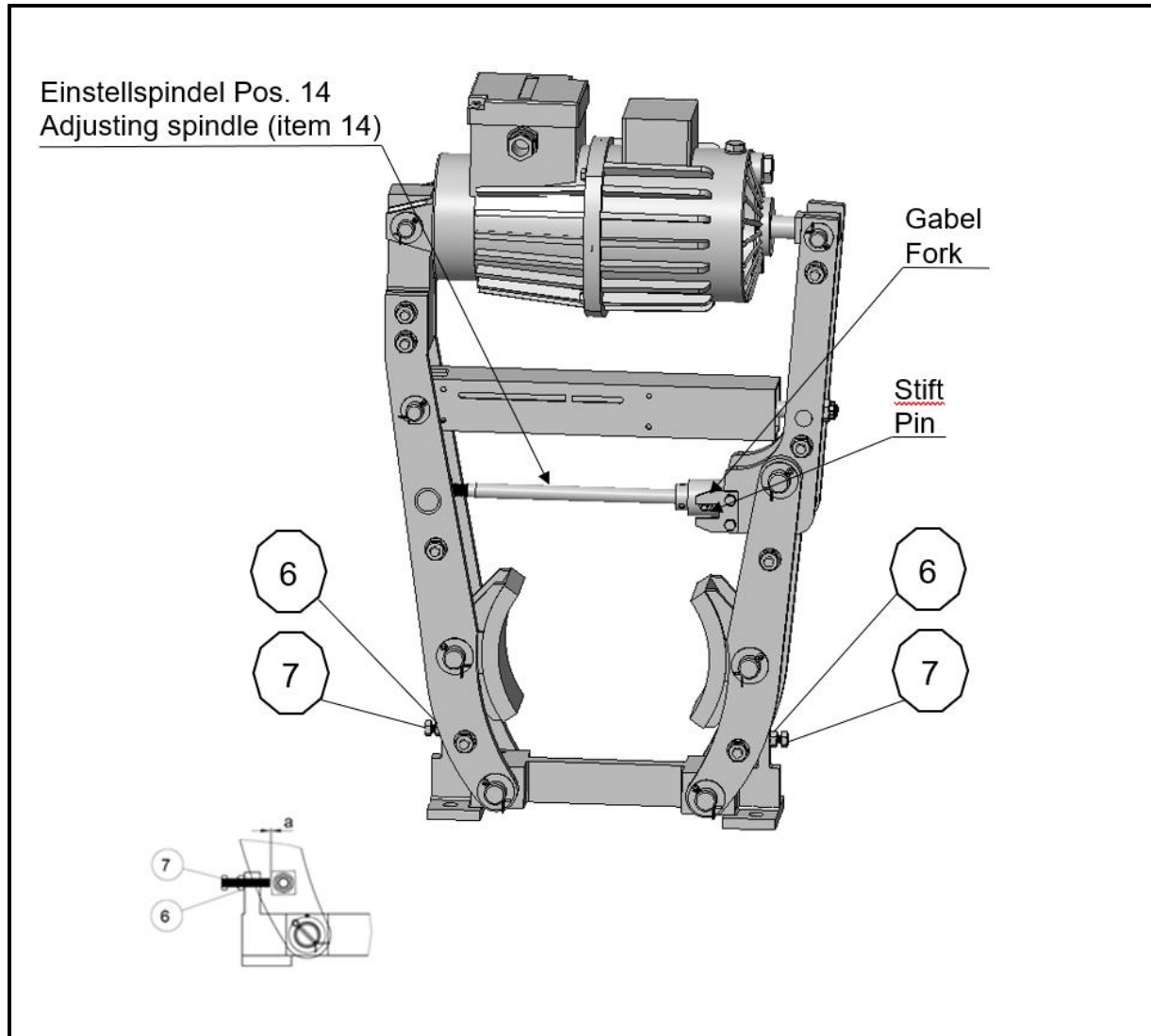

Fig. 8.3

Maintenance setting / adjusting FEA automatic wear compensator

- Apply the brake.
- For the purpose of adjusting, loosen the nut (item 6) and turn the adjusting screw (item 7) by approx. 2 revolutions out of to increase the gap.
- The proper function of the automatic compensator can be easily evaluating by observing the piston stop-position across the times. It must remain constant! If the devise doesn't work correctly little by little, the piston stops position will be lower and lower until the end position is reached, where the braking effect will miss with great danger for the personnel safety.
- With the adjusting screws (item 7), the total clearance of 3 mm on one side is evenly spread to 1.5 mm on each side Fig. 2.1 measure a on both side balancing. Once the adjustment has been carried out, secure the position of the adjusting screws (item 7) using the nuts (item 6).

RINGSPANN	Installation and operating instructions for Brake DT XXX FEA-XXX H-ST spring activated – electro hydraulically released	E 09.793e		
Issue: 12.05.2021	Version: 2	Drawn: BAHS	Checked: EISF	Pages: 22 Page: 14

Maintenance FEA manual setting / adjustment for changing brake pads with reset the automatic wear compensator

- Apply the brake.
- For the purpose of changing the brake pads, loosen the nut (item 6) and turn the adjusting screw (item 7) out of to maximum surface of the holder.
- Loosen the fork Fig. 8.3 and turn the adjusting spindle (item 14) back until you have enough free space to mount the new brake pads.
- Now you can loosen the old brake pads and move then the pads topward for easy exchange. The new pads mount in the same way fix the axes (item 3) the washer (item 4) and the split pin (item 5) don't forget to bend the split pin (item 5).
- Reassemble the fork Fig. 8.3 and activate the brake multiple times the automatic process will start and adjust the clear distance between the brake pads of approx. 3 mm.
- With the adjusting screws (item 7), the total clearance of 3 mm on one side is evenly spread to 1.5 mm on each side Fig. 2.1 measure a on both side balancing. Once the adjustment has been carried out, secure the position of the adjusting screws (item 7) using the nuts (item 6).
- If there is wear to the brake pad, the automatic process will start and the braking force setting must not be performed but the balancing measure a between the lever hast to adjust time by time to avoid uneven pad wear.



Important!

As the device provides the self-adjustment, no intervention is required for this function. By beginning it is valuable making sure that the device is working correctly, and have no been damaged during transportation or installation. The setting at the automatic brake will only balancing the measure a Fig. 2.1 between the lever to avoid uneven pad wear!

If the thruster rod like Fig. 8.4 right side representation full inside the thruster there is the danger you will loose the hole clamping force. This state must be avoid.



Important!

It's very important verifying the stop position of the piston, taking into account that it should not go closer than 10-15mm see Fig. 8.4 from its limit. It is recommended performing this inspection fairly often at the beginning of the installation activity. Yet, if after repeated intensive inspections, it is apparent that the piston stop-position remains quite unchanged, you can prolong the inspection frequency. If by braking, it is evident that the stopping intervention hasn't been as effective as usually expected, stop using the brake and check up the proper function of the automatic lining wear compensator.

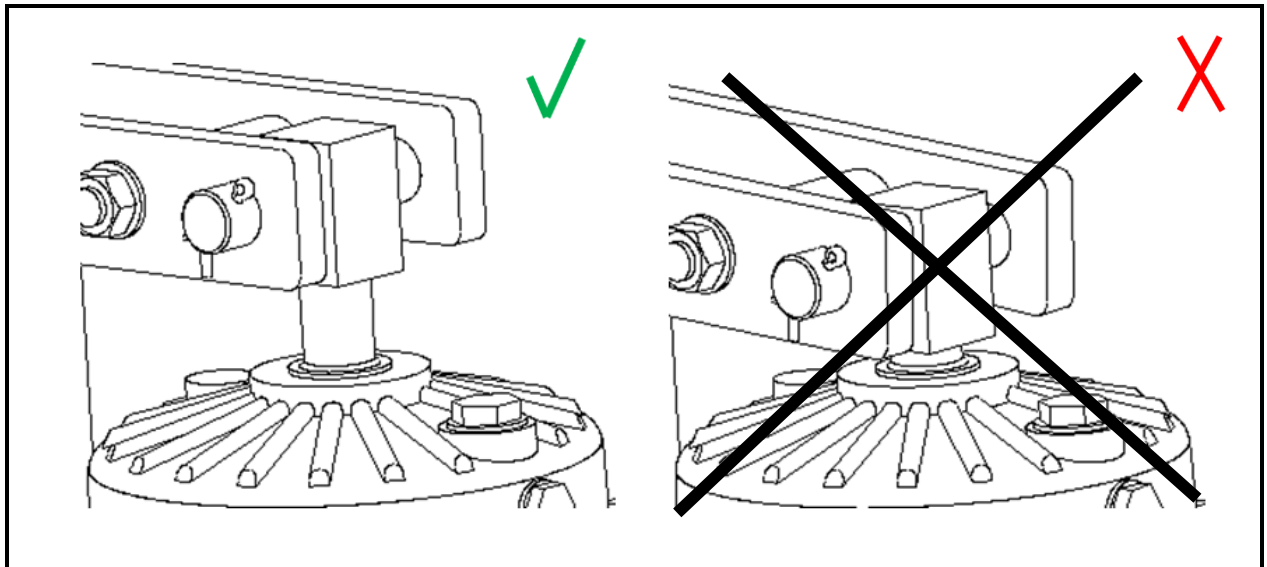

Fig. 8.4



Important!

Before start-up, the air gap must be adjusted to 1.5 mm on either side!

**Important!**

It must be ensured that the brake pad (item 2) do not grind on the brake drum while the brake is released!

**Important!**

If the brake is released by Hand release lever (item 9), this hand release lever must be removed once the brake has been installed to ensure a functional brake!

If the thruster rod like Fig. 8.4 right side representation full inside the thruster there is the danger you will loose the hole clamping force. This state must be avoid it is necessarily to adjust before!

The brake has an external adjustable braking spring (item 15) it is housed into a square tube provided with a scala easy torque setting for the brake over the adjusting nut (item 8) see Fig. 2.1 Before you change the setting the adjusting shaft is secured over a screw with a nut this has to be untie before setting and afterwards the screw hast to be fix and counter locked with the nut.

**Important!**

If you set the clamping force with the adjusting nut (item 8) too low the braking torque can be to low to hold the load!

9. Start-up

Only full-face contact of the two brake pad (item 2) on the brake drum as well as a rapid heating of the brake pads to approx. 200°C will ensure an optimal braking effect. It is therefore necessary to brake several times and for a short duration when the brake drum is rotating.

**Important!**

If the brakes are used as holding brakes, then the braking torques indicated in the catalogue will not be reached. Reductions of up to 50% of the braking torque are possible.

RINGSPANN	Installation and operating instructions for Brake DT XXX FEA-XXX H-ST spring activated – electro hydraulically released	E 09.793e	
Issue: 12.05.2021	Version: 2	Drawn: BAHS	Checked: EISF Pages: 22 Page: 17

10. Disassembling the brake



Life-threatening danger!

When disassembling the brake it is to be ensured that the entire drive train is secured against being switched on unintentionally. Rotating parts can cause severe injury. Rotating parts (e.g. brake drum) must be secured by the operator against unintentional touching.

The brake force can be reset by loosen the adjusting spindle (item 14) if you have the automatic brake dismantle the fork before. Then the brake pad, are free you can remove the screws that serve for fastening the brake to the machine frame. The brake calliper can now be removed from the mounting surface.



Information!

The installation of the brake if the drivetrain: motor, gearbox, something else and the brake drum is already install or you will change to a new brake if the brake is already installed. The exchange or installation of the brake is easy remove the down bolt of the right arm connection to the basement see Fig. 10.1. Before you remove the bolt please remove one split pin and the two locking grup screws for the bolt in the basement and than you can swing the arm aside replace the brake. The Installation use the other way around. Please secure the two grup screws with screw locking.

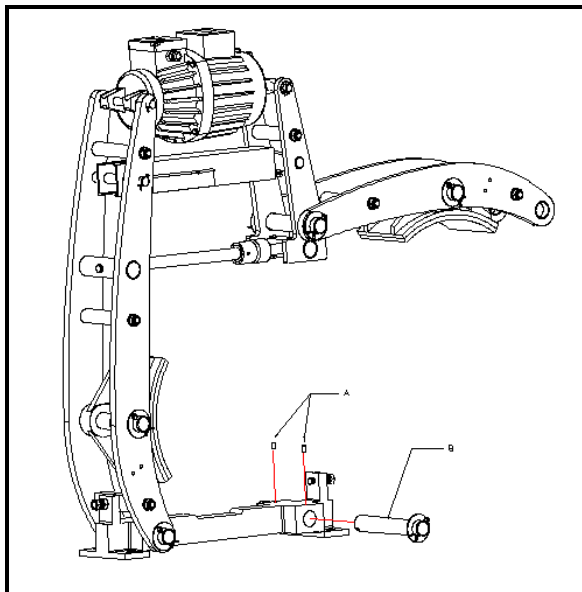

Fig. 10.1

RINGSPANN	Installation and operating instructions for Brake DT XXX FEA-XXX H-ST spring activated – electro hydraulically released	E 09.793e		
Issue: 12.05.2021	Version: 2	Drawn: BAHS	Checked: EISF	Pages: 22 Page: 18

11. Maintenance

11.1 General maintenance

Depending on environmental conditions or progressive aging and how much the brake is used in operation, maintenance is to be carried out on it at intervals of 4 to 12 weeks.

The following is to be carried out when performing maintenance:

- Check the brake pads for wear.
- Check that, when the brake calliper is released, the brake pads do not grind on the brake drum and that there is an even air gap on both sides.
- Check the screw connection of the brake.
- Check both brake calliper levers for ease of movement.
- Clean the bearing and sliding points.
- Grease the bearing, adjust spindle and sliding points.
- Check the thruster for tightness and Oil level every 5 year the thruster needs full service in Packing, Wiper, Bearings and Hydraulicoil please look into the thruster manual.



Important!

The brake pads must not come into contact with the lubricant!

11.2 Permissible pad wear and exchanging of the brake pad



Life-threatening danger!

Brake pad may only be changed when the system or the work machine is stationary!



Important!

The brake pads have a thickness of 8 - 12 mm when new. The residual lining thickness of 2 mm is necessary, the brake pads are always be exchanged in pairs. If you have no wear at the brake pad after 5 - 7 years working time you also have to replace the brake pads. Because of the brake pad age you will loose brake performance.

Only original RINGSPANN brake pads may be used.

RINGSPANN	Installation and operating instructions for Brake DT XXX FEA-XXX H-ST spring activated – electro hydraulically released	E 09.793e		
Issue: 12.05.2021	Version: 2	Drawn: BAHS	Checked: EISF	Pages: 22 Page: 19

Before exchanging the brake pads, ensure that the mass held by the brake is secured against moving, since parts of the brake need to be loosened for this purpose.

Open the brake with the prescribed voltage.

Loosen the nuts at the screws (item 6) both side. Turn the adjusting screw (item 7) and threaded rod (item 14) back until the brake pads (item 2) can be exchanged without any problems.

Dismantle the split pin (item 5), the washer (item 4) and the axes (item 3). The brake pad must be pushed topward for easy change process. Change the brake pads and assemble the axes brake pad (item 3) washer (item 4) and split pin (item 3). Please note don't forget to bend the split pin (item 5).

After exchanging brake pads, you must reset the brake torque and clearance as described in point 8.3.



Important!

If the brake is opened by manual hand release, this manual hand release must be removed again once the brake has been installed to ensure a functional brake! Split pin item 5 has to be bend!



Important!

After exchanging brake pads, a running-in process should be performed in order to reach the maximum brake torque.

12. Options

12.1 Mounting and connection of micro switch for position monitoring and pad wear control

Please note if you have the option micro switch the micro switch delivery mounted on the brake.

The micro switch cannot mount afterwards.



Life-threatening danger!

The micro switch may only be assembled and changed when the system or the work machine is stationary!

General data

Ambient temperature: -25°C ... +80°C
 Max. actuation frequency: 3600 operating cycles/hour
 Mechanical endurance: 20 million operating cycles
 Mounting position: any
 Safety parameters: B10d: 40,000,000 for NC contacts

Voltage of the micro-switch

Alternating current: AC15 (50÷60 Hz)

Ue (V)	250	400	500
Ie (A)	6	4	1

Direct current: DC

Ue (V)	24	125	250
Ie (A)	6	1,1	0,4

Protection against short circuits: fuse 10 A / 500 V type aM

Protection degree of the housing: IP67

In conformity with standard: UL 508, CSA 22.2 No.14

In conformity with the requirements of:

Low Voltage Directive 2006/95/EC, Machinery Directive 2006/42/EC and EMC Directive 2004/108/EC.

Connection diagram of the micro switch

Always connect the safety circuit to the NC contacts
(NC contacts: 11 - 12; 21 - 22 or 31 - 32)

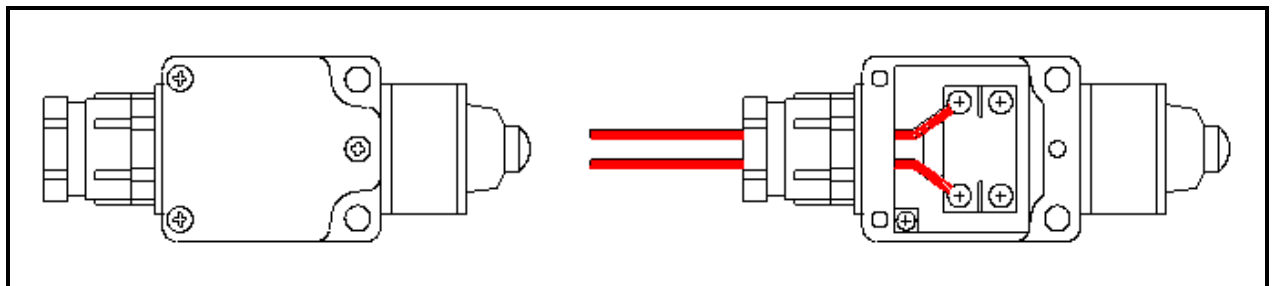

Fig. 12.1

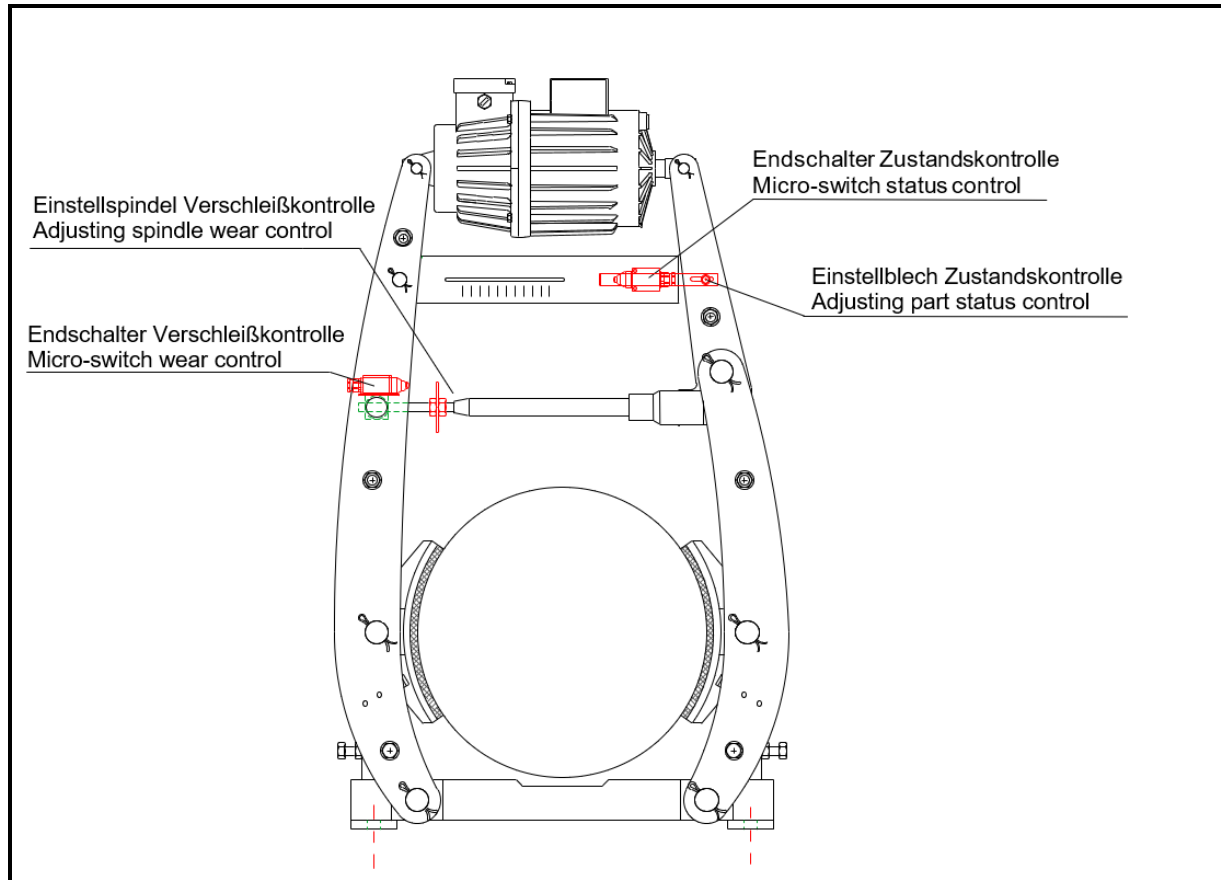

Fig. 12.2

The installation of the micro-switch brake on/off.

The micro-switch signaling brake on/off has the role of confirming the executed opening of the brake. Thank to this device, major damages to lifting motor can be prevented if the thruster fails.

The micro-switch is fixed with two screws at the brake. The adjusting of the switch can the operator make with the adjusting part (item 13). If the brake is open the micro-switch switches and the signal comes if no signal come loose the nut (item 12) Fig. 2.1 of the adjusting part and move the adjusting part (item 13) again the taster of the micro-switch until the signal comes fix the nut (item 12) of the adjusting part and test the proper function.

The installation of the micro-switch brake pad wear.

The micro-switch signaling brake pad wear warns that the lining thickness is coming to an end and jaw replacement is needed. Thank to this device, the rubbing of the bare jaw on the drum surface is avoided and major damages can be prevented. Keep in mind that without friction pad, the braking performance drops dramatically, this endangering the personnel safety.

The micro-switch is fixed with two screws at the brake. The adjusting of the switch can be done by the operator with the adjusting part. If the brake is open and the brake pads are new the adjusting part has the biggest distance if the brake pads wear comes to an end the adjusting part

washer pushes the taster of the micro-switch and give the signal. If the signal pad wear comes to soon the adjusting parts spindle brake pad wear has to be turn back.

Usually, the micro-switch signals for both functions become apparent on the operator's push button board

12.2 Hand release

If you have the option hand release there is a lever fixed mounted on the brake. If the operator turning the lever 180° degree see Fig. 12.3 the brake is open and out of function. The operator has to close the brake manual with the lever turning back downside the lever in the closed position now the brake can normally work.



Important!

If the operator open the brake over the hand release the brake is out of order. For the correct function you have to close the hand release!

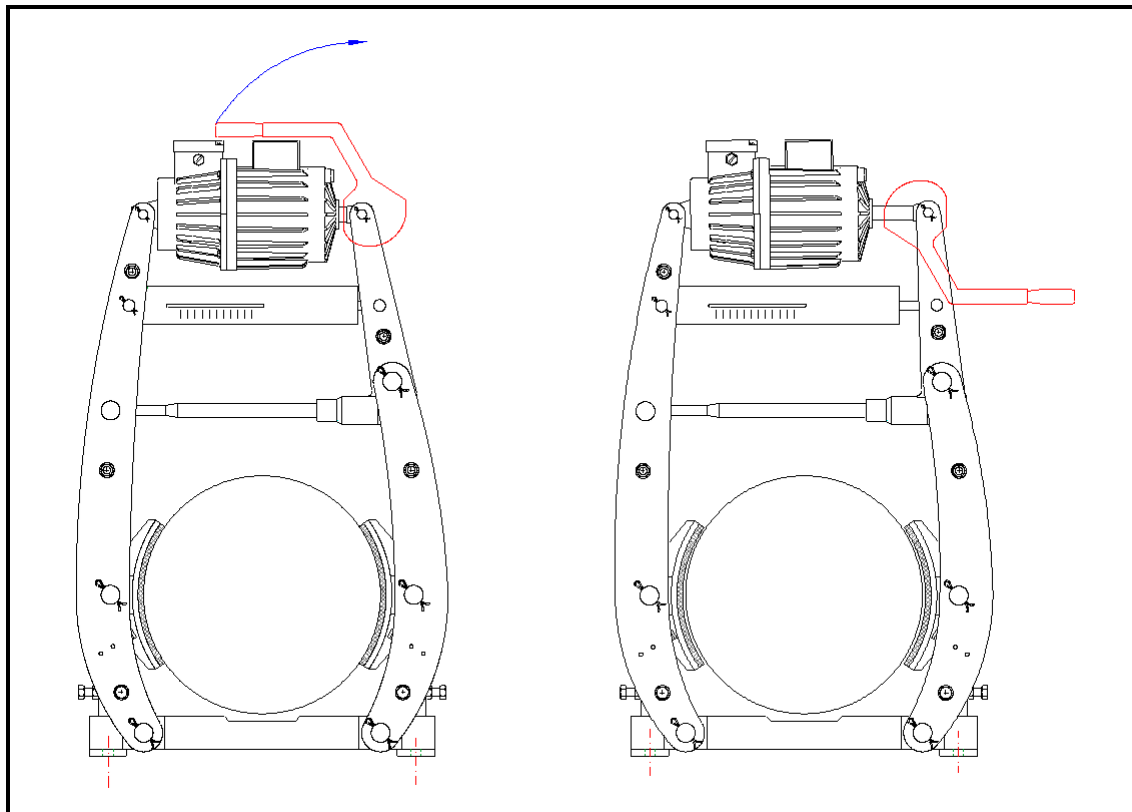

Fig. 12.3