

Installation and Operating Instructions for Brake Caliper DV 020 FEM

E 09.772e

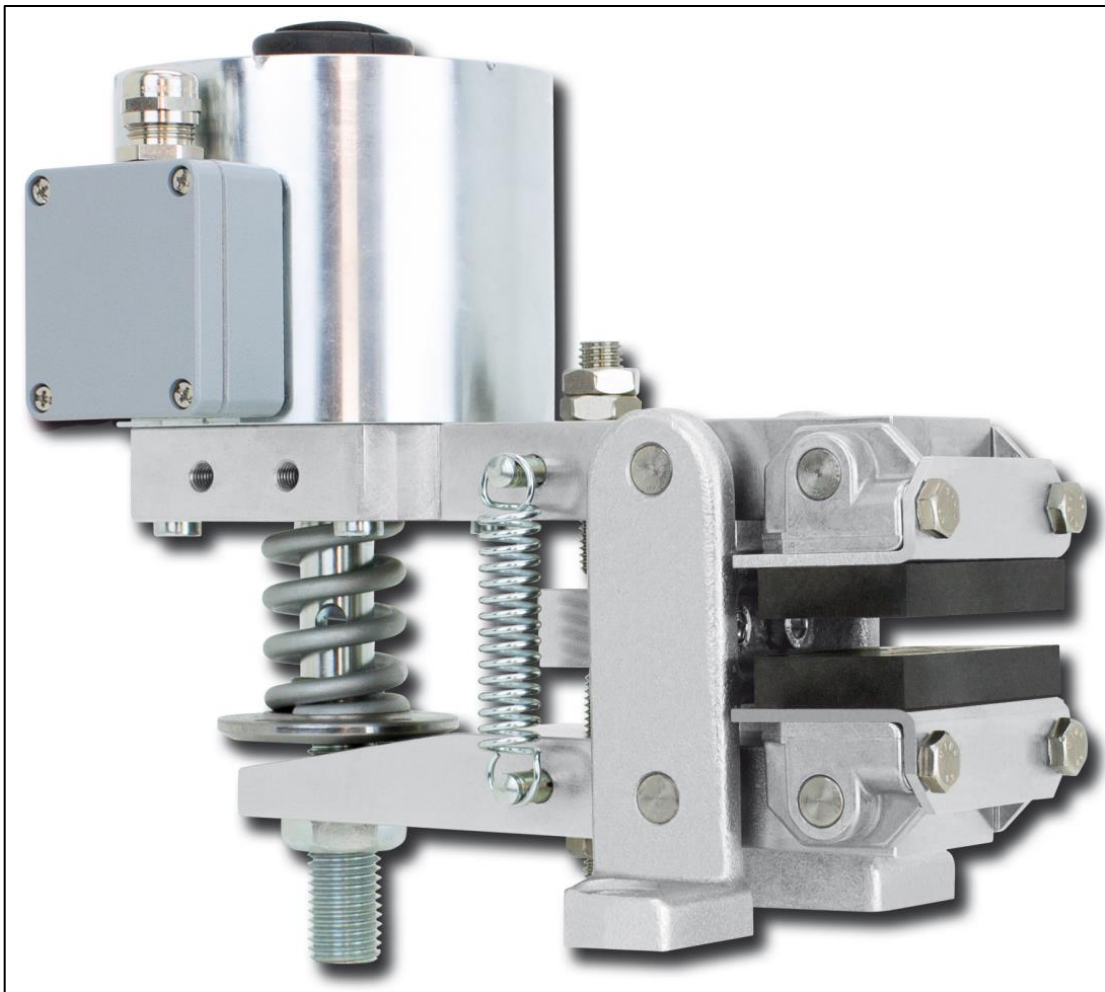

RINGSPANN GmbH

Schaberweg 30-38
61348 Bad Homburg
Germany

Phone +49 6172 275-0
Fax +49 6172 275-275

www.ringspann.com
info@ringspann.com

RINGSPANN	Installation and Operating Instructions for Brake Caliper DV 020 FEM, spring activated – electromagnetic released			E 09.772e	
Issue: 08.09.2021	Version: 2	drawn:MAYA	checked: EISF	Pages: 15	Page: 2

Important

Please read these instructions carefully before installing and operating the product. Your particular attention is drawn to the notes on safety.

These installation and operating instructions are valid on condition that the product meets the selection criteria for its proper use. Selection and design of the product is not the subject of these installation and operating instructions.

Disregarding or misinterpreting these installation and operating instructions invalidates any product liability or warranty by RINGSPANN; the same applies if the product is taken apart or changed.

These installation and operating instructions should be kept in a safe place and should accompany the product if it is passed on to others – either on its own or as part of a machine – to make it accessible to the user.

Safety Notice

- Installation and operation of this product should only be carried out by skilled personnel.
- Repairs may only be carried out by the manufacturer or accredited RINGSPANN agents.
- If a malfunction is indicated, the product or the machine into which it is installed should be stopped immediately and either RINGSPANN or an accredited RINGSPANN agent should be informed.
- Switch off the power supply before commencing work on electrical components.
- Rotating machine elements must be protected by the purchaser to prevent accidental contact.
- Supplies abroad are subject to the safety laws prevailing in those countries.

<p>This is a translation of the German original version!</p> <p>In case of inconsistencies between the German and English version of this installation and operating instruction, the German version shall prevail.</p>
--

RINGSPANN	Installation and Operating Instructions for Brake Caliper DV 020 FEM, spring activated – electromagnetic released			E 09.772e
Issue: 08.09.2021	Version: 2	drawn: MAYA	checked: EISF	Pages: 15 Page: 3

Contents

- 1 General information**
 - 1.1 Safety information
 - 1.2 Special safety information
- 2 Configuration, mode of operation and standards**
 - 2.1 Function
 - 2.2 Identification
 - 2.3 Standards, guidelines, protection class and certifications
- 3 Intended use**
- 4 Impermissible use**
- 5 Condition as delivered**
- 6 Handling and storage**
- 7 Technical requirements for safe operation**
- 8 Installing the RINGSPANN brake**
 - 8.1 General instructions regarding assembly and installation
 - 8.2 Installation instructions
 - 8.3 Electrical connection of the brake caliper
 - 8.4 Adjustment / readjustment of the friction block distance
 - 8.5 Connecting the signal cable of the friction block (option)
- 9 Commissioning**
- 10 Disassembling the brake**
- 11 Maintenance**
 - 11.1 General maintenance
 - 11.2 Permissible brake pad wear and replacement of the brake pads
 - 11.3 Emergency release
- 12 Installing the inductive proximity switch (option)**
- 13 EC-Declaration of Conformity**
- 14 Electrical connection drawing 4457-000002**
- 15 Drawing and parts list**

RINGSPANN	Installation and Operating Instructions for Brake Caliper DV 020 FEM, spring activated – electromagnetic released			E 09.772e
Issue: 08.09.2021	Version: 2	drawn: MAYA	checked: EISF	Pages: 15 Page: 4

1. General information

1.1 General safety instructions

Read these installation and operating instructions carefully before putting the brake into operation. Consider these instructions as well as the drawings in the individual sections. All work with and on the brake is to be carried out considering that "safety is top priority". Switch the drive unit off before carrying out work on the brake.

Rotating parts (e.g. brake disc) must be secured by the operator against unintentional touching.

1.2 Special safety instructions



Life-threatening danger!

When assembling, operating and maintaining the brake it is to be ensured that the entire drive train is secured against being switched on unintentionally. Moving parts can cause severe injury. Rotating parts (e.g. brake disc) must be secured by the operator against unintentional touching.

2. Configuration, mode of operation and standards

2.1 Function

The brake is a machine element with which accelerated masses can be safely slowed down. In combination with a brake disc, you have a complete brake for the effective safeguarding of machines and systems. Thanks to its universal design, it fulfils the following functions:

- As a holding brake, it prevents a stationary shaft from starting unintentionally.
- As a stopping brake, it brings a rotating shaft to a halt.

The brake force is generated by a spring (5) and the brake is released by means of an electromagnet (1). If the friction blocks (2) are worn out, the holding or braking torque decreases as the spring preload is reduced.

Max. Sound level during opening is 63 dB (measured according IEC 61672-2 "Fast", with max. clamping force).

2.2 Identification

These installation and operating instructions are valid for:

- the version DV 020 FEM, brake caliper attachment parallel to the brake disc.
- the DV 020 FEM with left-mounted electromagnet as shown in Fig. 2.1, for mounting on a 12.5 mm thick brake disc.
- the DV 020 FEM with right-mounted electromagnet.
- various types of brake-pads, and special brake pad materials.
- with manual spring force adjustment and special frame.
- the standard design, the cCSAus design and with proximity switch.

There is a type plate on the brake with a 16-digit part number. The exact design of the brake is defined by this article number only.

As well as these instructions, please also consider the catalogue data for the brake at www.ringspann.com and the drawings in the individual sections.

RINGSPANN	Installation and Operating Instructions for Brake Caliper DV 020 FEM, spring activated – electromagnetic released			E 09.772e
	Issue: 08.09.2021	Version: 2	drawn:MAYA	
		Pages: 15	Page: 5	

Example:

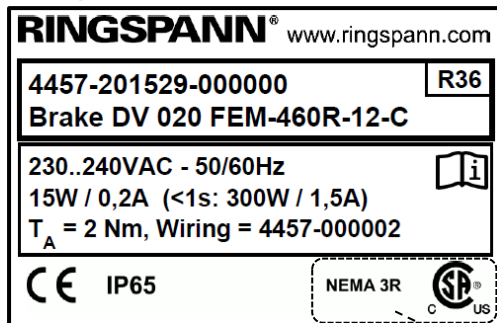

Identification:

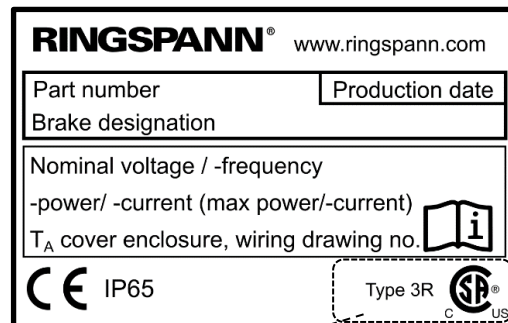

Only for cCSAus type

2.3 Standards, guidelines, protection class and certifications

The following standards and guidelines have been applied:

2014/35/EU	Low-Voltage Directive
DIN EN 61000-6-2	EMC – Immunity to interference for industrial areas
DIN EN 61000-6-4	EMC – Emission standard for industrial areas (with RFI filter 3515-090001-000000)
CSA C22.2 No. 14-13	Industrial Control Equipment (cCSAus Design)
UL 508	Industrial Control Equipment (cCSAus Design)
Electrical protection class:	IP65
Mechanical protection class:	IP10



In the sense of the Low-Voltage Directive 2014/35/EU.



cCSAus-Design:

Complies with Canadian and US American standard, Enclosure type 3R

3. Intended use

The brake has been designed for use as a holding and stopping brake.

Use for any other purpose will be deemed improper. Ringspann is not liable for any damage resulting from this; the user alone bears the risk.

4. Impermissible use

The brake must not be operated with a voltage higher than the value specified on the type label. In addition, unauthorized structural changes to the brake are not permitted. Ringspann shall not be liable for any damage resulting from this; the user alone bears the risk of such damage.

The standard UL 508 and CSA 22.2 No 14-13 is valid for ambient temperatures from 0°C to +40°C. Technically, lower or higher ambient temperatures are permissible. Consultation with Ringspann required.

5. Condition as delivered

When delivered, the brake has a clamping gap of approx. 8.0 mm between the friction blocks. When the electromagnet is actuated, the brake opens to the preset clamping gap of 13.3 mm = brake disc thickness 12.5 mm and an air gap of 0.4 mm on both sides between the brake disc and the friction blocks.

RINGSPANN	Installation and Operating Instructions for Brake Caliper DV 020 FEM, spring activated – electromagnetic released			E 09.772e
Issue: 08.09.2021	Version: 2	drawn: MAYA	checked: EISF	Pages: 15 Page: 6

6. Handling and storage

The brake weighs between 14 kg and 18 kg, depending on the version.

The brake is delivered preserved and can be stored in a closed, dry place for 12 months. Make sure that no condensation occurs. Humid storage rooms are unsuitable. If the brake is stored for a longer period than 12 months, as well as after each transport, the brake must be applied once to prevent the seals and wipers from sticking together.

7. Technical requirements for save operation

Fastening the brake to stable and low-vibration machine parts will ensure quiet braking without squeak.

8. Installing the RINGSPANN brake

8.1 General instructions regarding assembly and installation

Before installing the brake, the brake disc must be cleaned with alcohol (e.g. spirit (ethanol) or isopropyl alcohol) or with water-based tenside solutions (soapy water or the like).

If cleaning the brake disc with a diluent, acetone or brake cleaning agent, it must be ensured that these agents and no residues of these agents come into direct contact with the friction blocks. This must be ensured for pure holding brakes in particular, since no dynamic braking takes place that would remove any diluent residues from the brake disc.



Important!

Residues from oil and anti-rust agent considerably reduce the coefficient of friction and thus also the braking and holding torque!

8.2 Installation instructions

The standard brake calliper is attached to the machine part with two M12 - 8.8 screws. (The screws are not included in the scope of delivery)



Caution! Danger of injury!

When the brake caliper is released, the spring (5) is pretensioned. In the event that the electromagnet is not constantly supplied with the correct power supply, parts of the brake can suddenly move relative to each other!

Before assembly, check whether the mounting surface is level and the radial run-out between the brake disc and mounting surface is within a tolerance of 0.3 mm.

Check that the permissible parallelism of 0.2 mm between the brake disc and the mounting surface is not exceeded.

Check the axial movement of the brake disc. The axial movement shall not exceed $\pm 0,3$ mm.

The maximum permissible lateral run-out of the brake disc is 0.1 mm. A greater lateral run-out can cause the brake unit to rattle and shake.

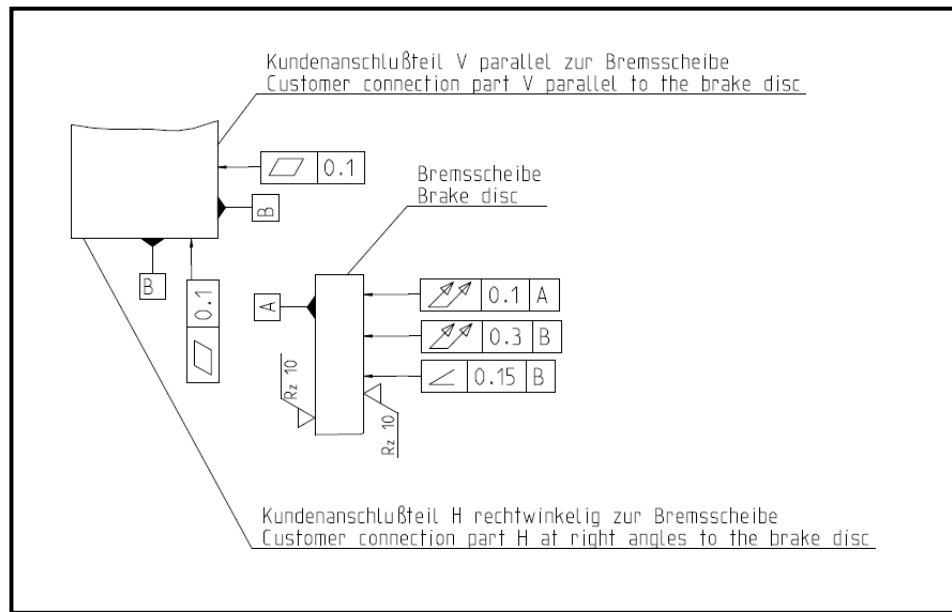

Fig. 8.1

The connecting plate for the brake as well as the brake disc must be checked for dimensional accuracy. For this purpose, the connection dimensions shown on the catalogue data sheet or installation drawing are to be checked. The standard distance between the connecting plate and the centre of the brake disc is 73 mm.

During installation, it is essential to ensure that brake pads are centred and in full contact with the brake disc (the midlines of the brake lever must point to the midpoint of the brake disc.).

Preparation for installation

Before mounting on the 12.5 mm thick brake disc, the brake must be released (opened). This is possible:

- with the aid of the electromagnet (1), provided that it is already connected to a power source (see Section 8.3).
- mechanically, by screwing on the "emergency release nut" (8), which you can find on the right lever (see chapter 15). To do this, pull off the rubber cap (9) at the back of the electromagnet and screw the "emergency release nut" onto the thread of the plunger.



Important!

Check whether the brake disc can rotate freely.



Important!

If the brake is released by screwing on the "Emergency release nut" (8), the "Emergency release nut" must be removed after installation of the brake for a functioning brake!

8.3 Electrical connection of the brake caliper



Caution! Danger of damage!

Before connecting the brake caliper to the power supply, check that your power supply corresponds to the specifications for rated voltage and mains frequency on the nameplate. In case of deviations, never connect the brake caliper, as otherwise the electronics and the electromagnet of the brake caliper will be destroyed.

The customer must provide suitable surge protection to prevent voltage peaks reaching the electronics.

Nominal voltage: 230..240 V AC, 50/60 Hz, single-phase.

Line protection : 6 A, **protection has to be ensured by the user!**

Outer diameter of the supply cable: 5 -10 mm (cCSAus); plug type (standard): 6-8mm.

Supply cable : 0,5-1,0 mm² (AWG 21- 18), fine wire, only copper cables are allowed.

When switched on, currents of up to 3 A occur for 0,7s. After that the current is about 0,6 A.

The brake caliper is actuated by switching the supply voltage on and off. On the electronics there is a free-wheeling diode which suppresses a switch-off overvoltage when the supply voltage is switched off. An autotransformer may be used for voltage reduction if its power rating is at least 0.3 kVA. The cable shall be selected according to the Canadian Electrical Code, part 1 or National Electrical Code (NEC).

Pass the cable through the cable gland and connect the wires L, N, PE according to figure 8.2 or 8.3. The connections L and N can be swapped. Tightening torque of the connector screw is 6 lb-in. See also chapter 14 "Electrical connection drawing 4457-000002".

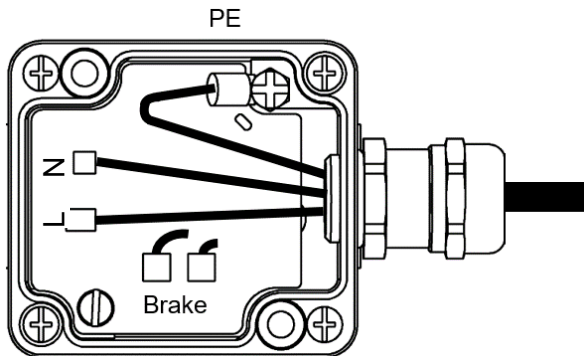

Fig. 8.2 (cCSAus)

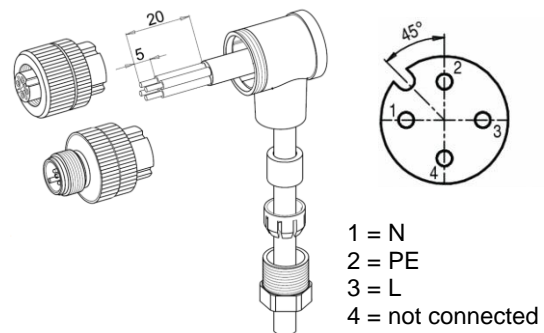

Fig. 8.3

8.4 Adjustment / readjustment of the friction block distance

The friction block distance is adjusted after mounting the brake caliper by adjusting / readjusting with the adjusting screw (3). The distance between the friction blocks and the brake disc on both sides should be approx. 0.4 mm when new. If the friction blocks wear out, brake force must be adjusted. When reaching a dimension of "X" = 44 mm (see chapter 15) at the latest, brake force adjustment and adjustment of the friction blocks must be carried out.



Attention!

Before commissioning, the air gap must be set to 0.4 mm on both sides!

The brake must be manually released with the "emergency release nut" (8) prior to adjustment work. To do this, pull off the rubber cap (9) at the back of the electromagnet and screw the "emergency release nut" onto the thread of the plunger.

Proceed as follows:

RINGSPANN	Installation and Operating Instructions for Brake Caliper DV 020 FEM, spring activated – electromagnetic released			E 09.772e
Issue: 08.09.2021	Version: 2	drawn: MAYA	checked: EISF	Pages: 15 Page: 9

- Loosen the two lock nuts for the adjustment work and turn the two set screws (3) M12x60 DIN 913 in the lever approx. 2 turns counterclockwise.
- Turn the screw (6) into the lever until it touches the tip of the plunger. Now adjust a small clearance of 0.2 to 0.4 mm on both sides between the friction blocks and the brake disc by turning the screw (6) further, whereby the friction blocks must not grind. It is advisable to press a friction block against the brake disc and adjust the required total clearance by means of a feeler gauge on the opposite friction block.



Tip!

The adjustable minimum clearance depends on the lateral run-out of the brake disc. The lower the clearance, the greater the wear reserve before the brake caliper has to be adjusted.

Depending on the position of the brake caliper and the brake disc axle, the laterally mounted electromagnet can generate a tilting torque, which causes an uneven air gap between the two friction blocks and the brake disc. In extreme cases, a friction block can even come into contact with the brake disc and the entire clearance is set at the opposite friction block. The result would be a constant rubbing of this friction block during operation. The air gap can be evenly adjusted by means of the set screws (3). Determine which friction block has the larger air gap. Turn the set screw on the lever clockwise and adjust an even air gap of 0.2 - 0.4 mm on both sides.



Important:

It must be ensured that the friction blocks (2) do not rub against the brake disc when the brake caliper is open.



Important:

If the brake is released by screwing on the "Emergency release nut" pos. 8, the hexagon nut must be removed for a functioning brake after installation of the brake!

If the power supply of the brake is switched off, the full braking torque (holding torque) is available.

8.5 Connecting the signal cable of the friction block (option)

Connect the signal cable to a 24V control voltage, e. g. via a signal lamp. If the maximum permissible friction lining abrasion limit is reached, contact to the neutral conductor is made and the signal lamp lights up.

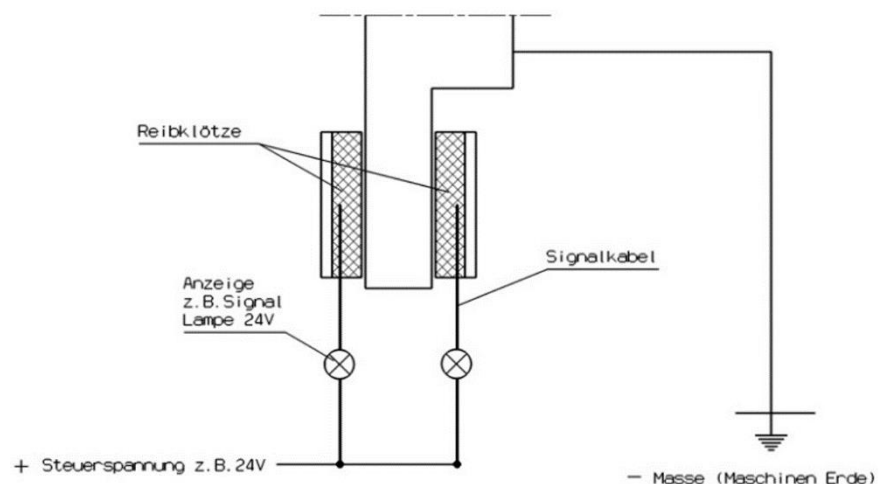

RINGSPANN	Installation and Operating Instructions for Brake Caliper DV 020 FEM, spring activated – electromagnetic released			E 09.772e
Issue: 08.09.2021	Version: 2	drawn:MAYA	checked: EISF	Pages: 15 Page: 10

9. Commissioning

Only full-face contact of the two friction blocks (2) on the brake disc as well as a rapid heating of the friction linings to approx. 200°C will ensure an optimal braking effect. It is therefore necessary to brake several times and for a short duration when the brake disc is rotating. This process is finished when the friction surface shows a contact pattern of at least 70 to 80%.



Important!

If the brakes are used as holding brakes, then the braking torques indicated in the catalogue will not be reached. Reductions of up to 50% of the braking torque are possible.

10. Disassembling the brake



Life-threatening danger!

When disassembling the brake it is to be ensured that the entire drive train is secured against being switched on unintentionally. Rotating parts can cause severe injury. Rotating parts (e.g. brake disc) must be secured by the operator against unintentional touching.



Important!

Make sure that no electrical voltage is applied to the brake caliper.

Remove the rubber cap (9) and screw on the hexagon nut (8) until an air gap between brake pad and brake disc is adjusted and the brake disc can be turned freely.

Remove the two screws M12 - 8.8 which serve to fix the brake. The brake caliper can now be removed from the mounting surfaces.

11. Maintenance

11.1 General maintenance

The brake caliper must be serviced at intervals of 4 to 12 weeks, depending on the application.

The following points must be checked during maintenance:

- Check the friction blocks for wear.
- Check that the friction blocks do not rub against the brake disc when the brake caliper is released, or that there is an even air gap of approx. 0.4 mm on both sides.
- Check the screw connection of the brake caliper to the machine part and the screw connection of the friction blocks for tight screw connection.
- Check the screw connection and the tight fit of the inductive proximity switch (optional).
- Check the screw connection of the electromagnet to the brake caliper lever.
- Check both brake caliper levers for easy moving.
- Clean the bearing and sliding points.
- Check the electrical wiring and connections.

RINGSPANN	Installation and Operating Instructions for Brake Caliper DV 020 FEM, spring activated – electromagnetic released			E 09.772e
Issue: 08.09.2021	Version: 2	drawn:MAYA	checked: EISF	Pages: 15 Page: 11



Important!

The friction linings (2) must not come into contact with lubricant!

11.2 Permissible friction lining wear and replacement of the friction blocks



Life-threatening danger!

Friction blocks may only be changed when the system or the work machine is stationary!



Important!

When new, the friction lining has a thickness of 12.5 mm. After 4.5 mm of wear or a residual lining thickness of 8 mm, the friction blocks must always be replaced in pairs. Only original RINGSPANN friction blocks may be used.



Important!

Before replacing the friction blocks, make sure that the mass held by the brake is secured against movement, as the brake must be released (opened) to change the friction blocks.



Important!

Make sure that no electrical voltage is applied to the brake caliper.

Release the brake by switching on the supply voltage. Secure the open position with the "Emergency release nut" (8). Turn the screw (6) back until the friction blocks can be changed easily and secure the screw again with the lock nut. After changing the friction block, you must readjust the braking torque and clearance as described in chapter 8.4.



Important:

If the brake is released by screwing on the "Emergency release nut" (8), the hexagon nut must be removed for a functioning brake after installation of the brake!

Finally, the new friction linings must be applied by braking briefly several times so that the brake can achieve the required braking torque (see chapter 9).

11.3 Emergency release

Open the brake caliper manually by screwing on the "Emergency release nut" (8) on the plunger until you can move the friction blocks on the brake disc.

12. Installing the inductive sensor (option)



Life-threatening danger!

The inductive sensor may only be changed when the system or the work machine is stationary!

The inductive encoders M12x1 length 65 mm are supplied separately. In the version with sensor monitoring, a fixture for the inductive sensors is mounted on the brake lever or can be ordered as an accessory.

Switching function: PNP (closer)

Switching distance: 6 mm flush-mountable

RINGSPANN	Installation and Operating Instructions for Brake Caliper DV 020 FEM, spring activated – electromagnetic released			E 09.772e	
	Issue: 08.09.2021	Version: 2	drawn: MAYA	checked: EISF	Pages: 15 Page: 12

Operating voltage: 10...30 V DC
No load current: < or = 10 mA
Voltage drop: < or = 2 V
Signal indicator: LED
Protection level: IP 67

Operating current: 0...200 mA
Connection: V1-plug
Polarity reversal-resistant: yes
Temp. range: -25 to +70°C

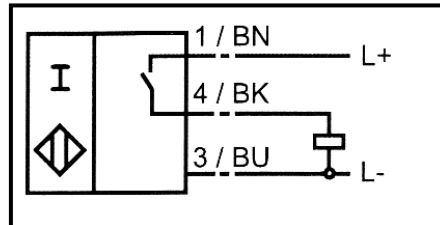

Fig. 12.1 Circuit diagram, PNP technology

Operating sequence for mounting or necessary replacement of the inductive sensor Brake closed (actuated):

- Mount the inductive sensor to the brake when the brake is powerless.
- Slide the inductive sensor into the lower slot of the sensor fixture until a distance of approx. 1 mm is reached between the inductive sensor and the collar of the sleeve (7).
- Connect the inductive sensor. Move the inductive sensor in the slotted hole from left to right until the LED of the inductive sensor lights up.
- Secure this position with the lock nut.
- Test the correct function by operating the brake several times. When the brake is closed, the LED of the inductive sensor must light up.

Sequence of operation for mounting or replacing the inductive sensor for the "Brake open" operating state (ventilated):

- Actuate the electromagnet and secure the open position with the "emergency release nut" (8).
- Mount the inductive sensor to the brake when the brake is powerless.
- Slide the inductive encoder into the upper slot of the sensor fixture until there is a distance of approx. 1 mm between the inductive sensor and the collar of the sleeve (7).
- Connect the inductive sensors. Move the inductive sensor in the slotted hole from the right to the left until the LED of the inductive encoder lights up.
- Secure this position with the lock nut.
- Remove the "emergency lock nut" (8) after installation of the inductive encoder.
- Test the correct function by operating the brake several times. When the brake is open, the LED of the inductive sensor must light up.

RINGSPANN	Installation and Operating Instructions for Brake Caliper DV 020 FEM, spring activated – electromagnetic released			E 09.772e	
	Issue: 08.09.2021	Version: 2	drawn: MAYA	checked: EISF	Pages: 15 Page: 13

13. EC-Declaration of Conformity

Note regarding EMC Directive 2014/30/EU

The brake is an uncritical equipment according to the EMC-Directive because of its passive operation. The brake can not be operated independently. After integration into a complete system, the brake can be evaluated according to EMC-Directive. To comply with DIN EN 61000-6-4, the mounting of a RFI filter (3515-090001-000000) is required as a general rule.

Note regarding EC-Machinery Directive 2006/42/EC

The product is a component for installation in a machine according to the EC-Machinery Directive 2006/42/EC. Together with other components, the product can meet safety-related applications. The necessary measures will emerge from the risk analysis of the machine. Built-in, the brake is part of the machine and the machine manufacturer assesses the conformity of the safety device on the Machinery Directive. The commissioning of the brake is only permitted if the machine fulfills the Machine Directive.

Note regarding REACH Directive No. 1907/2006

The brake is considered as a "product" and not as a "substance", and as such are not subjected to registration.

EC-Declaration of Conformity

We hereby declare that the following products are developed, designed and manufactured by our own responsibility in accordance with the Low-Voltage Directive.

RINGSPANN GmbH
Schaberweg 30-38
D-61348 Bad Homburg

Product: Electromagnetic released disk brake
Designation: DV020FEM
Sizes: 020
Types: 4457-2015xx-xxxxxx

Following standards and directives have been applied and complied with:

2014/35/EU	Low-Voltage Directive
DIN EN 61000-6-2	EMC – Immunity to interference in industrial areas
DIN EN 61000-6-4	EMC – Emission standard for industrial areas (with RFI filter 3515-090001-000000)
2011/65/EU	RoHS Directive
2019/2006	REACH
CSA C22.2 No. 14-13	Industrial Control Equipment (cCSAus Design)
UL 508	Industrial Control Equipment (cCSAus Design)

The commissioning of the brake is only permitted when the machine complies with the EC-Machinery Directive 2006/42 / EC.

ppa. Ernst Fritzeimer
RINGSPANN GmbH
Schaberweg 30-38
D-61348 Bad Homburg



Bad Homburg, 26.04.2020

14. Electrical Connection Drawing 4457-000002

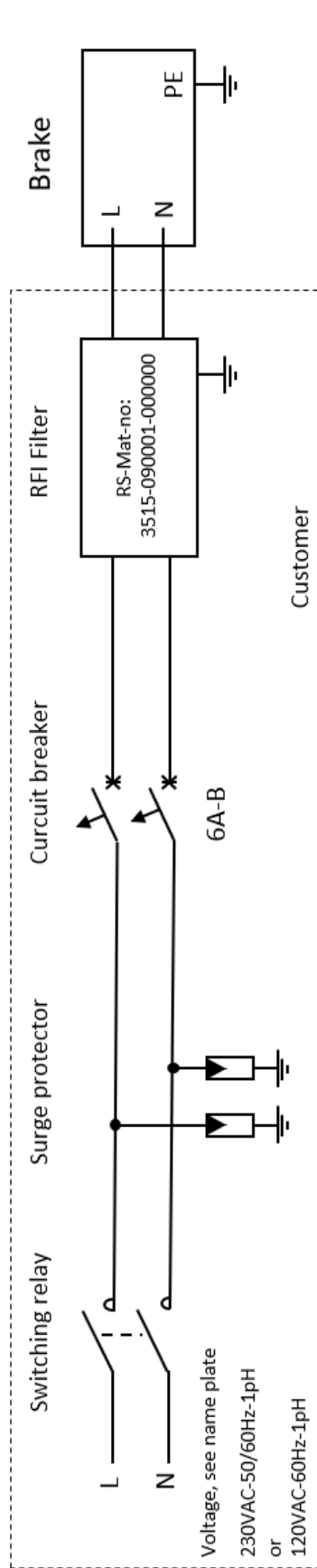
Electrical Connection, Drawing No. 4457-000002

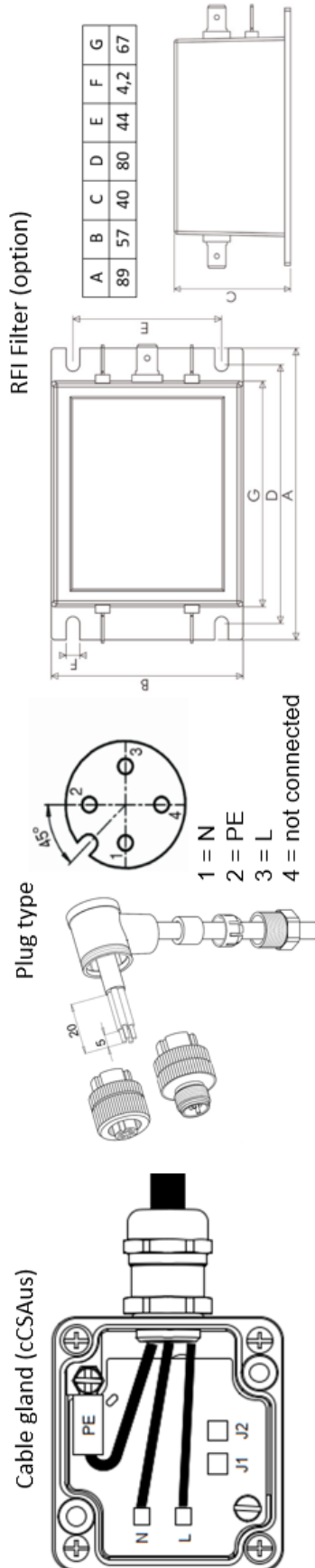

- N and L can be exchanged, PE is connected with a cable lug and screwed to the electronics box.
- Cable diameter: cable gland = 5 – 10mm ; plug type = 6 – 8mm.
- Conductor cross section: 0,5 – 1,0 mm² (AWG 21 – 18), fine wire strands.
- cCSAus-Type: The cables must be selected in accordance with the Canadian Electrical Code-Part 1, or the National Electrical Code (NEC). Only Cu cables may be used.
- See also chapter "8.3 Electrical connection" in the installation and operating instructions.



15. Drawing and parts list

Brake DV 020 FEM Standard with proximity switch (Specials see appendix).

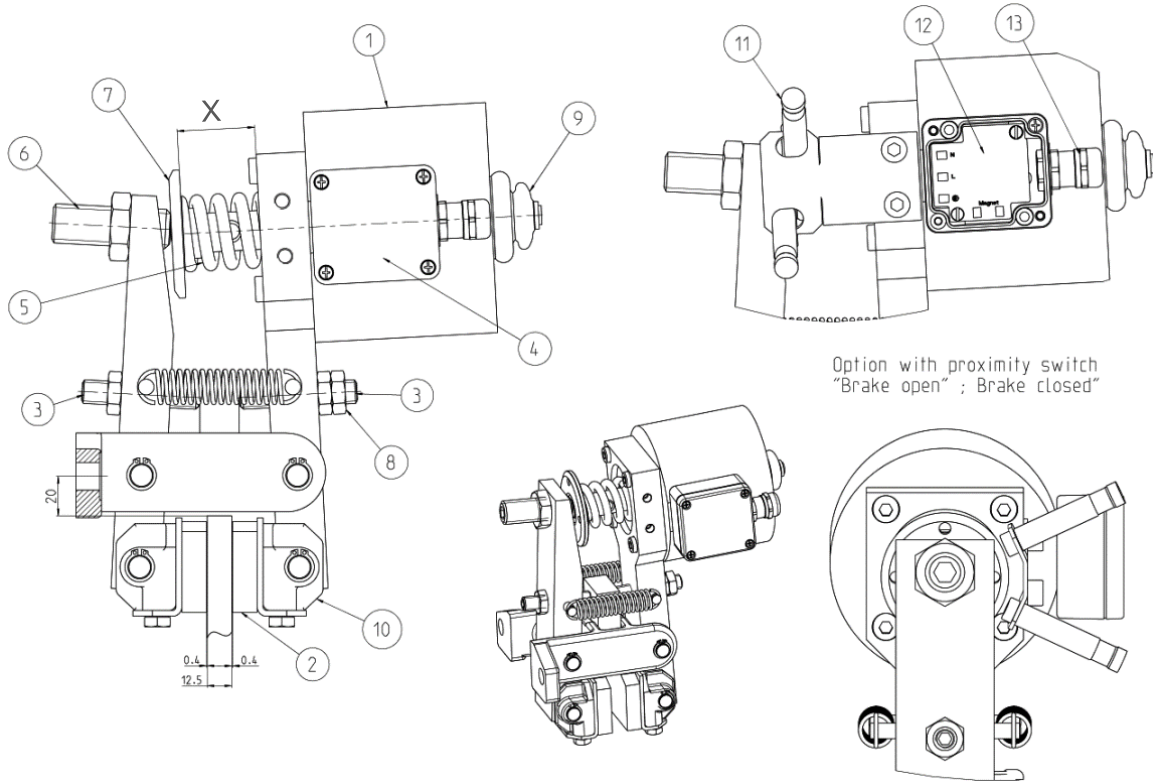

Part	Designation	Quantity
1	Electromagnet DV20FEM	1
2	Friction block	1 Set
3	Set screw M12x60 DIN 913	2
4	Electronic box	1
5	Spring	1
6	Set screw M20x60	1
7	Sleeve D 020FEM	1
8	Nut M12	3
9	Rubber cap	1
10	Swivel piece	2
11	Proximity switch with fixture	optional
12	Electronic board	1
13	Plug or Cable gland (cCSAus Design)	1